

# Aquasonic®

MULTICLIMATE AIRSPEAKERS

## Aguaceiro™

The Aguaceiro™ MultiClimate Airspeaker is more than water resistant—it's weatherproof in any environment! The blistering heat of the Arizona desert, a frigid outdoor terrace at a Swiss ski resort, seaspray at a beachfront condo in the Mediterranean, drenching rain in any region, your backyard—you name it, the Aguaceiro™ can handle anything that comes its way.

Experience superb sound in your outdoor living area with the Aguaceiro™ MultiClimate Airspeaker. The Aguaceiro™ is the most durable outdoor speaker available today, and it is designed to blend in to its surroundings. Clark Synthesis is so sure of the performance of the new Aguaceiro™, it comes with a limited lifetime warranty. This hardy all weather speaker comes ready to install with a weatherproof screen and mounting bracket.

*Why buy an outdoor speaker you'll have to replace in a few years when you can enjoy the Aguaceiro™ for life?*

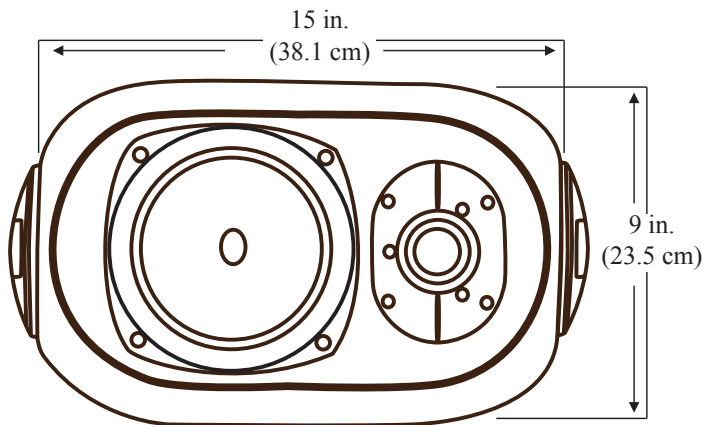

*\*The Aguaceiro™ comes with 4 ft. of weatherproof cable and is preassembled with protective screen and mounting bracket.*



- Specifications:** Frequency Response: 75 Hz to 20 KHz \* Power Handling: 100 Watts Continuous  
\* Impedance: 8 Ohms \* Dimensions: 15" (38.1cm) x 9.25" (23.5cm) x 8.5" (21.6cm) \* Weight: 12 lbs (5.4 kg)  
\* Recommended Amplification: 125 watts at 8 ohms



**CLARKSYNTHESIS**

Tel: 303-797-7500 Fax: 303-797-7501  
[www.clarksynthesis.com](http://www.clarksynthesis.com)