



CLARKSYNTHESIS

# *Installation Guide*

## PROSOUND429

**CAUTION:** THIS PRODUCT CONTAINS AN EXTREMELY POWERFUL MAGNET. DO NOT PLACE IN CLOSE PROXIMITY TO TUBE TV MONITORS, TUBE VIDEO MONITORS, AND MAGNETIC MEDIA.

### Table of Contents

Important Product Information	2
Product Overview	3
Mounting Bracket Installation	4
Drum Throne Installation	5
Stage/Platform Installation	6
Troubleshooting/Contact Information	8
Warranty	9



# IMPORTANT PRODUCT INFORMATION

---

1. **DO NOT DROP THE PROSOUND429-** The Prosound429 can be damaged both internally and externally if dropped. Damage caused by dropping the Prosound429 is not covered under the warranty.
2. **DO NOT EXPOSE THE PROSOUND429 TO HIGH DISTORTION LEVELS-** Exposing the Prosound429 to high levels of distortion may damage the unit. This type of damage is not covered under the warranty. If the Prosound429 stops playing, it is likely that the built-in protection circuit has activated. In the event this happens, turn the amplifier off for approximately 60 seconds to allow the circuit to reset. Turn down the volume on the input signal and amplifier. Operate the system at lower volume levels to avoid overloading the Prosound429.
3. **USE CAUTION WHEN MOVING OR TURNING DRUM THRONES-** If using this Prosound429 on a drum throne, insure the Prosound429 is protected from hitting the stand or other components. When sitting down on, or standing up from, the drum throne, insure the throne does not tip over. If the throne falls over, the Prosound429 may be damaged. Do not spin the throne with the Prosound429(s) attached. Severe damage may occur. These types of damage are not covered under the warranty.
4. **INSTALL AND USE TC-101 AMPLIFIER INTERFACE-** Install the TC-101 Amplifier Interface in-line between the amplifier and the Prosound429. This device is intended to dampen peak signals that may damage the Prosound429. Damage caused to the Prosound429 by failing to use the Amplifier Interface will not be covered under warranty.
5. **CABLE PLACEMENT-** Use caution when running the cable from the amplifier to the Prosound429. Do not lay the cable in high-traffic areas where tripping or entanglement may occur.
6. **DO NOT CARRY PROSOUND429 BY ITS CABLE-** Never carry the Prosound429 by its cable. This can damage the strain relief and internal wiring of the Prosound429. Damage of this type will not be covered under the warranty.
7. **DO NOT REMOVE THE STRAIN RELIEF-** Removing or altering the strain relief fitting connecting the wire to the Prosound429 may permanently damage the Prosound429. This fitting is carefully installed at the factory. Any alteration or adjustment of this fitting will void the warranty.
8. **AVOID EXCESSIVE HEAT-** Exposure to excessive heat will result in internal temperatures that can cause damage to the components. Damage caused by neglect will not be covered under warranty.
9. **STORAGE-** Insure the components are adequately protected when storing or transporting.
10. **USE PROPER AMPLIFICATION-** Insure the Prosound429 is being powered by an amplifier that is stable at 4 ohms and delivers at least 125 to 150 watts into 4 ohms into each Prosound429. If the lights inside the TC-101 Amplifier Interface are flashing brightly, turn down the gain on the amplifier and volume of the input signal going to the Prosound429.
11. **VOLUME CONTROLS-** Do not use with external volume controls rated at less than 150 watts.

# PRODUCT OVERVIEW

---

## **The Prosound429 is perfect for:**

- Drum Thrones
- Staging
- Platforms and Risers
- Keyboard Stands
- Piano Seats

## **PRODUCT FEATURES:**

The Prosound429 Package consists of (1) Prosound429, (1) TC-101 Amplifier Interface, (2) Speakon Connectors, (1) Gig Bag, and all of the hardware for mounting the Prosound429.

With the Prosound429 being the most powerful transducer available from Clark Synthesis, it is the clear choice for inclusion in our ProSound Package. Clark Synthesis designed the full-frequency Prosound429 to meet the demands found in many Pro Sound applications.

The TC-101 Amplifier Interface serves as a protection device to limit potentially damaging peak signals often found in Pro Sound applications. Using the TC-101 will help the user adjust volume levels going to the Prosound429, all while adding an additional layer of protection for the Prosound429.

To simplify the connections to and from the TC-101 Amplifier Interface, two speakon connectors come with the TC-101. These connectors provide a quick way to connect the amplifier and Prosound429 to the TC-101.

The gig bag serves as a handy storage case for transporting the Prosound429.

An amplifier is required in order to operate the Prosound429. Clark Synthesis recommends using an amplifier that is stable at 4 ohms that can deliver at least 125-150 watts into 4 ohms (per Prosound429).

# MOUNTING BRACKET INSTALLATION

The Prosound429 is most-commonly mounted using the mounting bracket assembly (see diagram below). This assembly, which comes with the Prosound429, is easily installed on a variety of surfaces.

1. To install this assembly, determine the location for the mounting bracket (insure the placement of the bracket allows for adequate spacing for the Prosound429. On drum thrones, insure the Prosound429 will not hit the stand once it is mounted). Secure the mounting bracket using screws.
2. Next, insert the threaded stud into the threaded hole on the mounting bracket. Insure the stud is turned into the bracket at least 8 or 9 full revolutions (maximum of 10 revolutions).
3. Spin two jam nuts onto the threaded stud, tightening one nut down against the mounting bracket to insure the threaded stud is secured to the bracket.
4. Finally, place the Prosound429's brass mounting nut onto the threaded stud. Insuring not to crossthread the brass nut, gently turn the Prosound429 5 to 6 complete revolutions. If you feel resistance, stop immediately. **CAUTION: DO NOT OVERTIGHTEN.** Spin the jam nut on the stud down to the brass nut and, using two wrenches (one on the jam nut and one on the brass nut), tighten the jam nut against the brass nut.

**CAUTION: DO NOT TIGHTEN THE JAM NUT TO THE BRASS NUT BY TURNING THE Prosound429. THIS WILL RESULT IN SEVERE DAMAGE TO THE Prosound429 AND WILL VOID THE WARRANTY.**

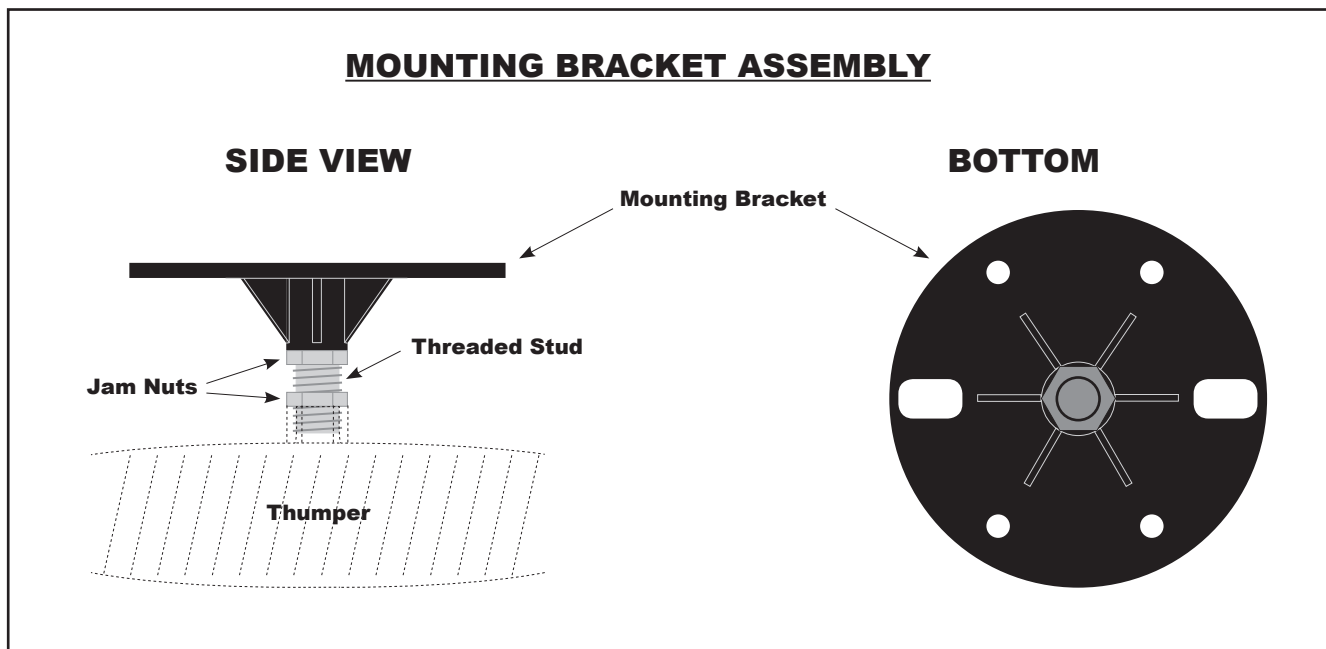

# DRUM THRONE INSTALLATION

- 1 If you are using a Clark Synthesis seat, there are pre-mounted T-nuts in the base of the seat that are ready to receive the threaded stud. The number of T-nut options is dependent on the type of seat you have purchased, i.e., round or bicycle. Round seats have two T-nuts, bicycle seats have three (one in the back and one on each side). Since round seats can be rotated to place the Prosound429 in the desired location under the musician (front, back, or side), the selection of the T-nut to use is not critical. However, for bicycle seats, you may either mount the Prosound429 toward the back or in one of the more forward positions on the sides. For the best feel, it is usually best to mount the thumper under the part of the throne closest to where you sit (some people sit forward, others sit on the center/back).

Screw the threaded stud into the desired T-nut. Place one lock washer and two jam nuts on the threaded stud. Tighten one jam nut and the lock washer to the T-nut in the seat. Go to the instructions in this manual in the Mounting Bracket Installation section and follow Step 4 to complete the installation.

- 2 If installing on another manufacturer's seat, determine the desired location for the Prosound429 (front, back, side, more than one Prosound429?). Follow the instructions in this manual in the Mounting Bracket Installation section.

NOTE: Taping the wire across the dome may help prevent damage to the unit in the event the throne is turned, creating tension on the wire. This, however, is not a guaranteed method for preventing damage. Excessive stress to the wire may result in severe damage. This damage is not covered under warranty.

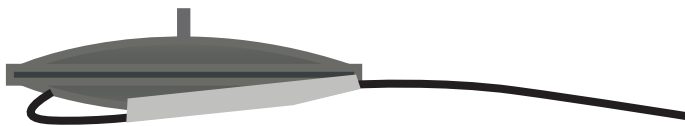

- 3 Determine the location for the TC-101 Amplifier Interface. The TC-101 may be mounted inside a rack or placed on a rack shelf. If the TC-101 is placed in a remote location beyond the reach of the wire on the Prosound429 (approximately 3 ft.), attach another segment of wire from the Prosound429 to the TC-101. Connect the wire from the Prosound429 to one of the speakon connectors. Connect another wire from the amplifier (not supplied in the Prosound429 Package) to the other speakon connector. Plug the speakon connector coming from the amplifier into the Input connector on the TC-101. Plug the speakon connector coming from the Prosound429 into the Output connector on the TC-101.
- 4 Feed the input signal from your musical equipment/mixing console into the amplifier. Turn the gain on the amplifier down. Play the instrument as you slowly increase the gain on the amplifier. While playing, insure the TC-101 is not flashing too brightly inside. Continue testing the output level by monitoring the feel from the Prosound429 and the degree of flash coming from the TC-101. If the TC-101 is flashing brightly, this means the signal is too strong and the gain level needs to be lowered. Adjust the gain until the desired level is achieved. Some low-level flashing from the TC-101 is acceptable.

# STAGE/PLATFORM INSTALLATION

There are at least two ways to mount a Prosound429 to a stage or platform. For wooden stages, you can install a bridge between support joists of the staging. For metal frame staging or freestanding wooden platforms you can install the mounting bracket directly to the staging surface. Either of these types of installation are effective for activating the stage's/platform's surface.

NOTE: The Prosound429 designed to be mounted in a horizontal orientation. Mounting the Prosound429 vertically may cause premature failure.

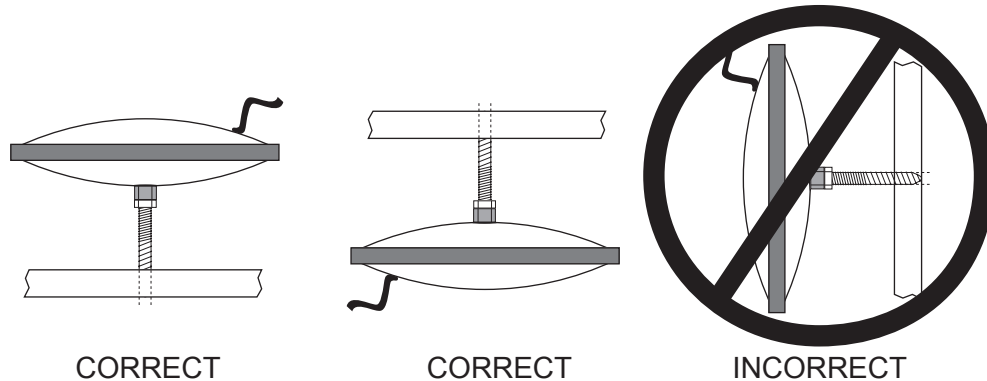

- 1 For a more permanent installation on wooden stages, you may want to use the bridge mount method. Determine which type of bridge you want to use (straight or arched). If you are using the arched bridge style, cut the arch using the dimensions shown below (CAUTION: DO NOT CUT INTO EXISTING JOISTS).

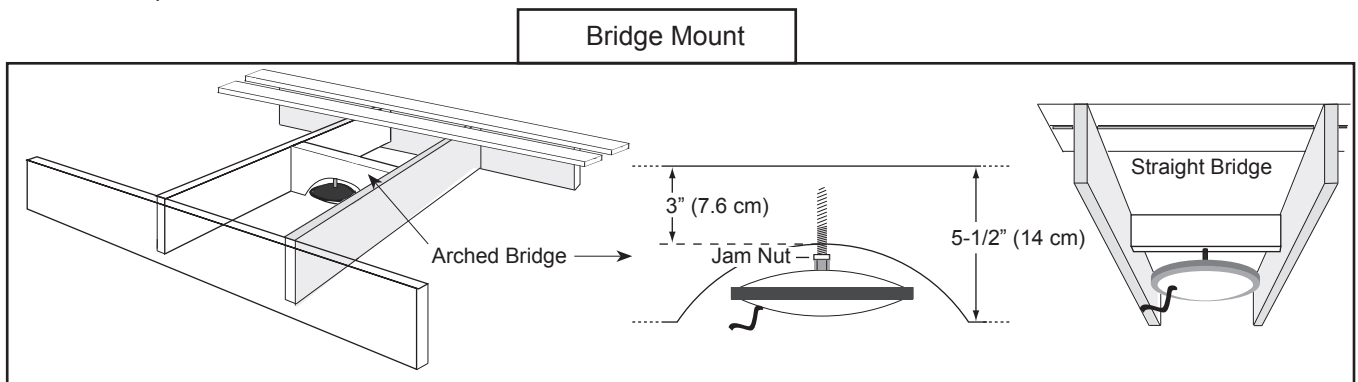

- 2 Cut the length of the bridge board to fit snugly between the two support joists. The bridge board must be at least 3/4" (1.9 cm) thick. Screw the bridge board securely between the support joists. Drill a 5/16" (.79 cm) pilot hole that is approximately 2 inches (5 cm) deep into the joist.
- 3 Place two (2) Jam Nuts on the Hanger Bolt and tighten the nuts together (this will allow you to turn the bolt with a wrench). Turn the Hanger Bolt into the joist up to the place on the bolt where the threads change from wood threads to machine threads. Loosen and remove one of the Jam Nuts.

# STAGE/PLATFORM INSTALLATION (CONT.)

- ④ Lifting the Prosound429 up to the Hanger Bolt, place the Prosound429's brass mounting nut onto the machine thread side of the Hanger Bolt. Insuring not to crossthread the Hanger Bolt into the brass nut, gently turn the Prosound429 5 to 6 complete revolutions. If you feel resistance, stop immediately.

CAUTION: DO NOT OVERTIGHTEN.

- ⑤ Spin the Jam Nut that is still on the Hanger Bolt down to the brass nut and, using two wrenches (one on the Jam Nut and one on the brass nut), tighten the Jam Nut against the brass nut.

CAUTION: DO NOT TIGHTEN THE JAM NUT TO THE BRASS NUT BY TURNING THE Prosound429. THIS WILL RESULT IN SEVERE DAMAGE TO THE Prosound429 AND WILL VOID THE WARRANTY.

## SURFACE MOUNT

To mount the Prosound429 directly to the surface of a stage or platform, you must first attach the mounting bracket or install the T-nut included in the hardware package. To install the mounting bracket, follow the instructions for this installation under the Mounting Bracket Installation section. To install the T-nut, you will have to drill a 1/2 in. hole through the stage. From the top side, set the T-nut with a hammer until it is flush with the stage's surface. Proceed with the installation of the threaded stud as noted in step 2 of the Mounting Bracket Installation section (reduce the revolutions to 5 or 6, not 8 or 9).

If possible, place the Prosound429 in the center of the area you are trying to activate (see the example diagram below). The Prosound429 can be mounted above or below the platform, as long as the Prosound429 is mounted horizontally (see diagrams in previous section). If the Prosound429 is mounted above the platform, insure it is protected from being kicked or bumped by feet or other moving objects (CAUTION: SEVERE DAMAGE MAY OCCUR IF THE Prosound429 IS KICKED).

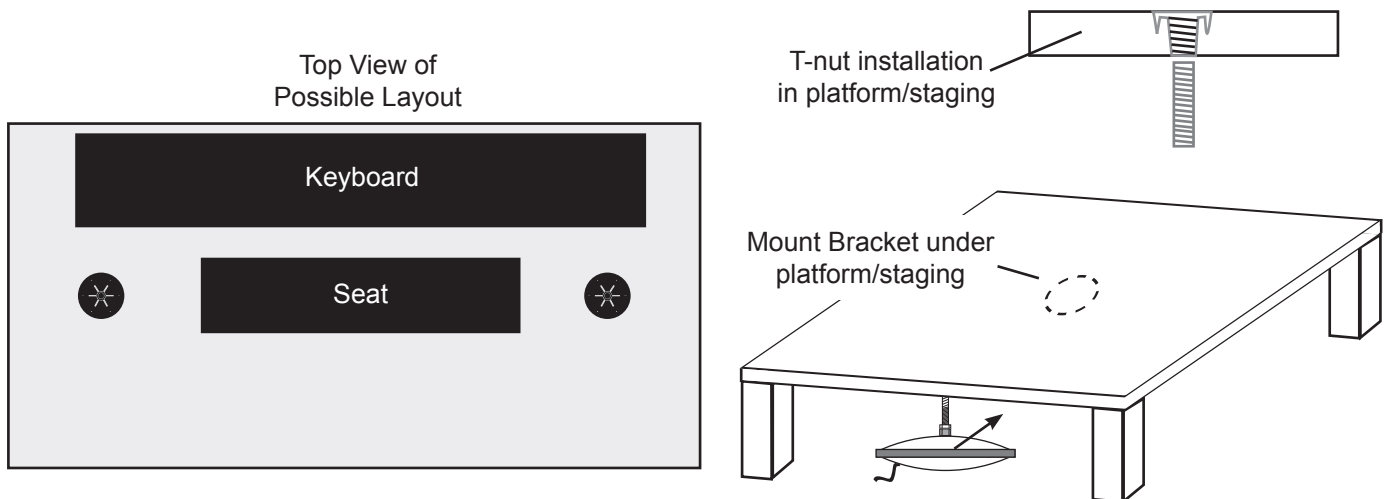

# TROUBLESHOOTING

---

## **The Prosound429 stopped working:**

- If the Prosound429 stops playing, it is likely that the built-in protection circuit has activated. In the event this happens, turn the amplifier off for approximately 60 seconds to allow the circuit to reset. Turn down the volume on the audio system and amplifier. Operate the system at lower volume levels to avoid overloading the Prosound429.
- If the Prosound429 still does not play, check to insure all wiring connections are properly connected and that output is coming from the audio system.

## **The lights in my TC-101 Amp Interface are flashing very brightly:**

- This indicates the input audio signal going to the Prosound429 is too high.
- Turn the gain/volume down on the audio equipment and the amplifier until the lights are not flashing as brightly (no flash to a slight flash is acceptable).

## **The Prosound429 is buzzing:**

- Insure the Prosound429 is not touching another object (e.g., drum stand, equipment rack, etc.)
- Check the tightness of the jam nuts and threaded stud to insure they are secure.
- This may indicate the input audio signal going to the Prosound429 is too high, turn the gain/volume down on the audio equipment and the amplifier until the buzzing stops.

## **There is not enough output (feel) in the throne:**

- Move the Prosound429 directly under where you sit on the drum throne.
- Move the Prosound429 directly under where you stand on the platform.
- Insure the drum throne you are using is not overly thick or padded
- Consider adding a second Prosound429 to your throne or platform

**For additional questions/concerns/issues, contact Clark Synthesis or check our web site at [www.clarksynthesis.com](http://www.clarksynthesis.com).**

Clark Synthesis, Inc.  
Phone: 303-797-7500  
Fax: 303-797-7501  
Web: [www.clarksynthesis.com](http://www.clarksynthesis.com)  
Email: [info@clarksynthesis.com](mailto:info@clarksynthesis.com)



# WARRANTY

---

## United States Warranty and Return Policy - PROSOUND429

### WARRANTY

Clark Synthesis, Inc. warrants the Prosound429 to be free from defects and workmanship under normal use for a period of two (2) years from date of original purchase. For industrial or commercial use, the warranty period is six (6) months.

Should warranty service be necessary, Clark Synthesis, Inc. will (at its discretion) repair or replace the defective merchandise with equivalent merchandise at no charge.

This warranty is valid for the original purchaser and is not extended to subsequent owners. Any applicable implied warranties are limited in duration to a period of the express warranty as provided herein beginning with the date of the original purchase at retail, and no warranties, whether expressed or implied, shall apply to this product thereafter. Some states do not allow limitations on implied warranties; therefore these exclusions may not apply to you. This warranty gives you specific legal rights; however, you may have other rights that vary from state to state.

### WHAT IS NOT COVERED

This warranty is valid only if the product is used for the purpose for which it was designed. It does not cover the following:

- Damage caused by excessive heat
- Damage through negligence, misuse, accident, or abuse
- Damage caused by incorrectly mounting the Prosound429
- Damage due to not using an appropriate amplifier
- Freight damage
- Items repaired by an unauthorized repair facility
- Items damaged due to amplifier clipping and/or distortion
- Items purchased from unauthorized individuals or dealers
- Cost of shipping product to Clark Synthesis, Inc.
- Return shipping on non-defective items

### RETURN POLICY

New, unused items purchased from us may be returned within 7 days of the purchase date. Please note: Clark Synthesis will only accept returns for items that are received in their original packaging, in undamaged and re-sellable (new) condition. Manuals, accessories, and everything else that came with the unit must be included as well. If your return does not meet these conditions, you will be charged a 25% restocking fee or have the merchandise returned to you at your expense. Non-defective merchandise can also be returned after 7 days for a 20% restocking fee. Shipping charges for all non-defective returns or exchanges are not refundable.

### WHAT TO DO IF YOU NEED WARRANTY OR SERVICE

If it becomes necessary for you to return defective merchandise, call Clark Synthesis at (303) 797-7500 or visit [www.clarksynthesis.com](http://www.clarksynthesis.com) and you will be given a Return Authorization Number. Follow the instructions provided by our customer service staff, use suitable packing materials (preferably the original shipping boxes), and make sure to write your Return Authorization Number on the outside of your box when sending your return to us. Orders that are returned without a Return Authorization Number may be refused by our returns department! Remember to include a dated proof of purchase from an authorized dealer. Return freight must be prepaid by the customer: items received freight collect will be refused. If the returned product is found to contain a manufacturing defect not caused by the customer and a replacement product is sent to the customer, Clark Synthesis, Inc. will pay to ship the replacement product to a domestic location (within the USA) via ground shipping methods. Costs associated with a) shipping replacement products intended to replace defective merchandise not caused by a manufacturing defect, b) replacement products shipped outside the USA, or c) replacement products shipped via shipping methods other than ground shipping will be paid for by the customer.

Make sure the following is included in your package:

- Product to be returned (repacked in original shipping containers)
- Return Authorization Number printed on the outside of the box
- Copy of original invoice with Return Authorization Number printed on it

### INTERNATIONAL WARRANTY

Contact your International Clark Synthesis dealer or distributor concerning specific procedures for your country's warranty policies.